



**GANESH
MACHINERY**
The Edge in Cutting.

20869 Plummer St. Chatsworth, CA 91311

Toll Free: 888-542-6374 (US only)

Phone: 818-349-9166 | Fax: 818-349-7286

www.ganeshmachinery.com

GANESH GMV-2F (9" X 50") Precision Milling Machine



- **3-Horsepower Variable Speed Head**
- **60 – 4500 RPM Spindle Speeds**
- **Class-7 *Super Precision* Spindle Bearings**
- **Hard-Chrome Plated and Mirror Ground Quill**
- **Hard-Chrome Plated X & Y Axis Ways**
- **9" x 50" Table Dimensions**
- **Coolant Proof Halogen Lamp Standard**

STANDARD GANESH GMV-2F MACHINE FEATURES



Machine Construction:

- Meehanite Castings, fine grain and high density cast iron using the superior Meehanite process yields superior vibration dampening and improved surface finish and tool life



Bed ways:

- Turcite-B Premium Coated way surfaces
- Hard Chrome plating for X & Y axes
- Hardened and Ground Dovetail slideways in X, Y, & Z
- Hardened and Ground Table

Spindle:

- 3-HP Variable Speed head for superior metal removal capability
- Spindle supported by two precision angular contact and one ball-bearing to ensure rigidity
- ABEC Class-7 matched Super Precision spindle bearings
- **Spindle Runout 0.00008" maximum – guaranteed! (R8 spindle)**
- Spindle made from one-piece Ni-Cr alloy steel with inner taper hardened and ground
- Hardened, ground and polished precision Back Gear for quiet spindle operation
- Forward/ Reverse switch housed in an oil-tight switch box

Milling Head Gear and Quill:

- Power quill feed with 3-feeds and adjustable feed stop & automatic feed trip release
- Hardened and Ground Quill – **Hard chrome plated and polished** for a long service life
- Dynamically balance pulleys supported in precision bearings

Machine Features:

- Multiple knee and table locks for superior cutting rigidity
- Head tilting system locked to ram with 6 T-bolts, instead of 3 like others use
- T-slots ground to 5/8" for an accurate reference edge - fits standard workholding T-nuts
- One-Shot Metered Central Lubrication System for slideways and lead screws
- Built-in coolant pump
- Chip-Tray is included
- Water resistant halogen lamp is included
- Painted dark grey (RAL7011)
- Instruction Manual, Tools and Tool Box all included
- Large compliment of parts and accessories in stock to ensure continued operation

**THE BEST MILLS IN THE INDUSTRY,
BACKED BY A FULL - SATISFACTION GUARANTEE**

STANDARD GANESH GMV-2F MACHINE SPECIFICATIONS

TABLE –

Table Size: W x L (50" optional)	9" X 50"	(230 X 1270mm)
T-slot Width / Quantity	5/8" / 3	on 2.5" centers
Table Load Capacity	400 pounds	(200 kg)
Table Surface to Floor Dimension	32' – 48"	(820 -1226mm)

MACHINE TRAVELS & CAPACITY –

Table Travel – Longitudinal – <u>X Axis</u>	38" (38" opt.)	(966mm)
Table Travel with Power Feed	35"	
Cross Travel – <u>Y Axis</u>	12"	(305mm)
Vertical Knee Travel – <u>Z Axis</u>	16"	(406mm)
Overarm (ram) Travel	12"	(305mm)
Overarm Swivel	360°	
Spindle Nose-to-Table Surface	0" – 18.5"	(0 - 469mm)
Spindle Centerline to Column Face	6.75" – 18.75"	(171 – 476mm)
Leadscrews with ground pitch surface (X & Y)	0.200" per rev.	(ballscrews optional)
Adjustable scale ring display resolution	0.001"	(5mm)
Ways – X, Y, & Z Axes – Hard Chrome Plated	Hardened & Ground Dovetail Ways	

SPINDLE HEAD –

Spindle Motor	Vari-Speed	
Spindle Taper (hardened & ground)	3-HP, 3-Phase 208–240 vac	
Spindle Runout	R-8 (ISO NST 30-taper optional)	
Spindle Bearings ABEC-7 matched set	0.00008" maximum runout (0.002mm)	
Variable Speed Spindle	Class-7 bearings	
Head Tilt (Left-to-Right)	60 – 4,500 RPM	
Head Tilt (Front-to-Back / Up-Down)	90° – 0 – 90°	
Head Swivel on Turret	+45°– 0 – -38°	
	360°	

Quill –

Quill Diameter	3-3/8"	(85.725mm)
Quill Travel – Manual & Power Feed	5"	(127mm)
Quill feeds – With Trip Release - Inch	0.0015", 0.003", 0.006"	
Quill feeds – With Trip Release - Metric	0.04mm, 0.08mm, 0.16mm	

DIMENSIONS & WEIGHT –

Machine Weight	2,222 lbs.	(1010 Kgs)
Coolant Capacity	8.7-Gallons	(33 liters)
Electrical Requirements - 208 – 240 vac,	3-Ph., 60 Hz., 9.5-amps	

**Ganesh GMV-2F machines are manufactured in
Our Certified ISO 9001 Factory in TAIWAN.**

Machine Layout Diagram

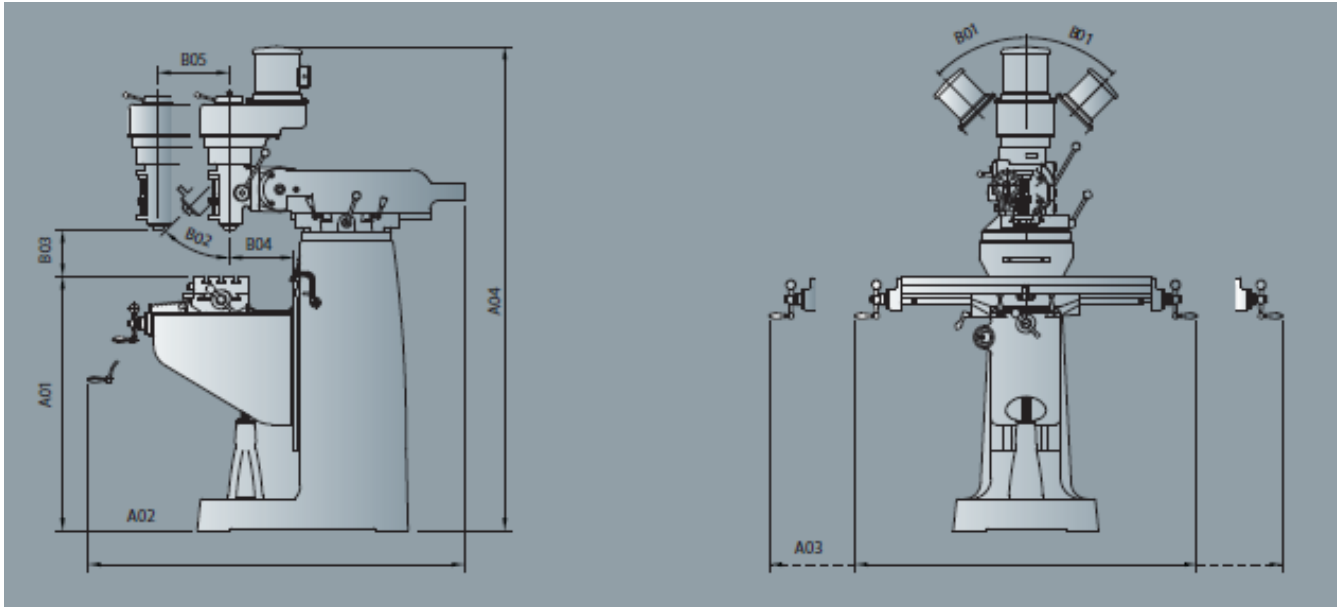

Width-A03 58", Depth-A02 63' -75", Height-A04 79"



Unique backlash adjustable double nut design with oversize contact face for both enhanced rigidity and accuracy with easy backlash adjustment.

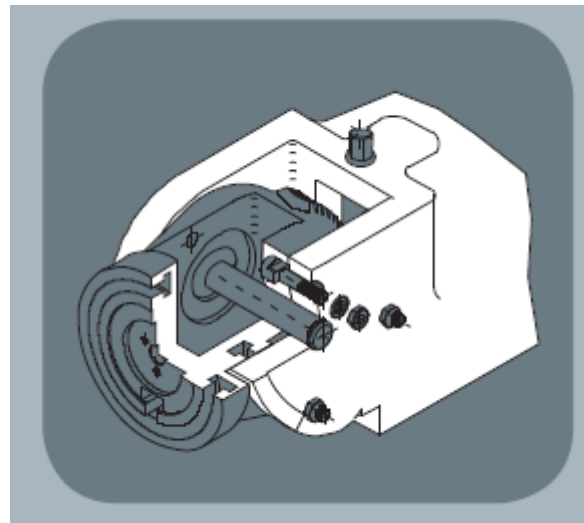

Patented head knuckle provides extra rigidity at any angle and uses a 6 T-bolt lock-down configuration for better stability.

Prices and specifications subject to change without prior notice.