



**GANESH
MACHINERY**
The Edge in Cutting.

20869 Plummer St. Chatsworth, CA 91311
Toll Free: 888-542-6374 (US only)
Phone: 818-349-9166 | Fax: 818-349-7286
www.ganeshmachinery.com

GANESH GBM-6024 CNC Bed Mill **With Class-7 Super-Precision Fafnir® Spindle Bearings and Box Ways**



- **Axis Travels - X 59", Y 24", Z 20"**
- **16" x 76" Table**
- **CAT #40 Spindle (BT#40 Available)**
- **Production-Style Retention-Knob Drawbar – No Noisy Air-Motor!**
- **Box Ways in Y & Z Axis**
- **Front Wrap-Around Table Guard**
- **Coolant & Chip Tray**

COMBINING STRENGTH & ACCURACY FOR HIGH-PRODUCTIVITY

STANDARD GBM-6024 BED MILL FEATURES

Massive Cast Iron Box Way Construction –

The GBM-6024 machine casting was CAD designed using FEA (Finite Element Analysis). Strategically place heavy cast ribs reinforce the internal structure to intensify rigidity. **The heavy-duty casting and the box way design dampens vibration for superior machining capability for enhanced tool life and fine surface finishes.** Slide ways are coated with Turcite®-B antifriction material to minimize stick/slip characteristics and to ensure long-term accuracy under demanding cutting conditions. The machine is constructed of all certified premium Meehanite® castings for optimal strength and rigidity.

Slide Ways –

- Axis Travel X-Y-Z: 59” x 23.6” x 20” travels for a large variety of work sizes
- Hardened and Ground oversized Column mounted box ways for the Vertical Slide way
- Hardened and Ground extra wide Saddle box ways for the cross axis
- Hardened and Ground longitudinal dovetail ways for the table axis
- Turcite® Type-B *Red-Furon* Coated ways on all axis minimize stick/slip & improve accuracy
- Precision C3-grade preloaded double-nut ballscrews in all 3-axis
- Y & Z axis way covers included for added safety and protection of the machine

Spindle -

- CAT- 40 or BT- 40 taper spindle for maximum rigidity
- 4,000 RPM Spindle w/ an AC Inverter Spindle Head
- Matched pair of Fafnir® ABEC Class-7 *Super-Precision* P4 spindle bearings (Made in England)
- Spindle Runout within a maximum of 0.00004”
- Push-Button retention-knob style power tool changer drawbar. “No noisy air motor!”

Features -

- Automatic Metered Lubrication for slideways and ballscrews
- Built-in coolant pump with chip & coolant collector tray
- Built-in coolant system features 3-coolant lines with separate flow control valves
- Built-in leveling ledge allows for easy leveling of the machine low to the floor
- Water resistant 70-watt adjustable halogen work lamp is included
- Inspection Report on accuracy, Instruction Manual, Tools and Tool Box all included

BE EFFICIENT! BE PRODUCTIVE! BE PROFITABLE!

GBM-6024 CNC BED MILL SPECIFICATIONS:

Axis Travels:

• Table Travel (X-Axis)	59.05"	1,500 mm
• Cross Travel (Y-Axis)	23.62"	600 mm
• Vertical Head Travel (Z-Axis)	20.08"	(27.95" opt.)
• Spindle Nose to table top	3.74" – 24.4"	(4.3" – 32.3" opt.)

Axis Feedrates:

• Rapid Feedrate	394 ipm	10,000 mm/min
• Cutting Feedrate	196 ipm	5,000 mm/min
• Axis Servo Motors	2.8-HP	2 KW

Spindle:

• Spindle Motor	15-HP peak, (10-HP 30-minute duty-rated)
• Spindle RPM (Spindle Inverter Drive)	60 - 4,000 RPM
• Spindle Tooling Size	40-taper CAT (BT Available)
• Spindle Tool Retention	Air Powered retention-Knob style Drawbar

Milling Table:

• Table Size	15.98" X 75.98" 406 mm X 1,930 mm
• Table Slot Width	5/8" ground table slot 15.9mm
• Table Load Capacity	1,210 pounds 550 kg (Table load is greater when centered)

Way Surface Type:

• Box Ways – Table (X-Axis)	Hardened & ground dovetailed ways
• Box Ways – Cross slide (Y-axis)	Hardened & ground box ways
• Box Ways – Vertical column ways (Z-Axis)	Hardened & ground box ways

Accuracy:

• Positioning Repeatability	±0.0001"	0.005 mm
• Positioning Accuracy	±0.0002"	0.01 mm

Dimensions:

• Floor Space Required (L x W x H)	95" x 173" x 92.5"	2400 x 4400 x 2350
• Machine Weight	7700 lbs.	3500 kgs
• Coolant Capacity	10-Gallons	
• Power Requirements	220 vac ±5%,	

**The Ganesh GBM - 6024 is manufactured in our
Certified ISO 9001 Production Facility in TAIWAN.**

Rotary Options

Expand your machine capability to another dimension.

Our 4-axis CNC can eliminate 2-setups by allowing you to machine 3-sides in one operation.

Complicated 4-axis parts can be machined in just one set-up.

Includes 4th axis wiring preparation & VRNC-210 4th - Axis CNC rotary table with the following features:

- worktable diameter 8.26" 210mm
- center height 6.30" 160mm
- Ø center bore Ø 45mm H7
- work load capacity 165 lbs 75 kg
- minimum input increment ... 0.001°
- table rotational speed 44 rpm

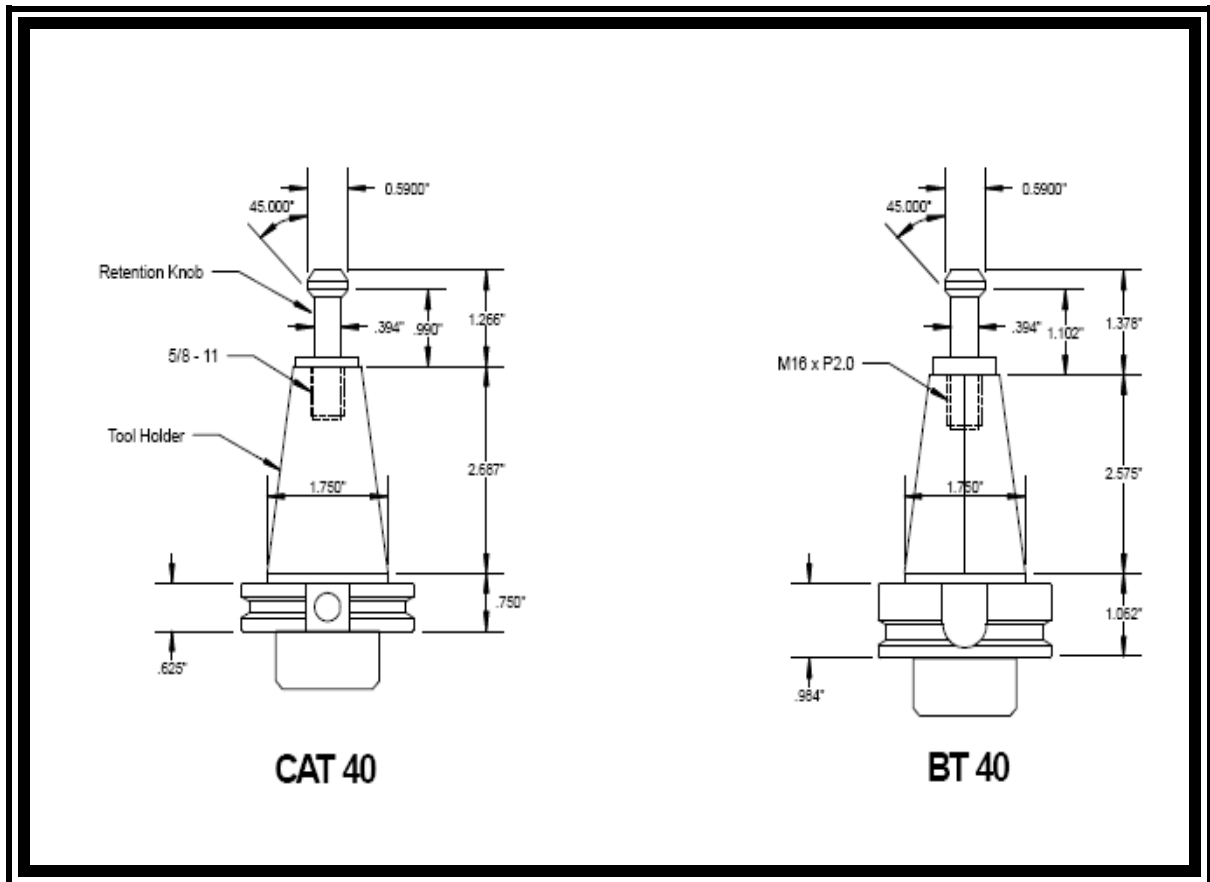

YOUR CHOICE OF CAT-40 or BT-40 TAPER TOOL HOLDERS

FAGOR 8055MC CNC CONTROLLER – 4th AXIS CAPABLE

The Fagor 8055 MC Control System is perhaps the most versatile CNC in existence due to its Dual Operating System. In one mode, it is a very powerful ISO G-code control System and, in the other mode, it features **Icon conversational programming with highly interactive graphics**, which make even complex tasks easy to program - **regardless of the operators experience level**.

No prior CNC programming knowledge is required to operate this control.



Fagor CNC 8055 MC Control System

- **Icon Conversational Programming – 26 High-Performance Canned Cycles**
Rectangular Boss cycle, Round Boss cycle, Rectangular Pocket cycle, Circular Pocket cycles, Profile Pocked 2D & 3D cycles, Slot Milling, Profile Milling, Multiple Drilling cycles, Boring cycles, Reaming cycles, Arc bolt hole cycles, Random position cycles, Grid Pattern position cycles.
- 4-axis CNC + spindle all under full CNC control
- 4-axis simultaneous interpolation with full Linear, Circular and **Helical Interpolation**
- Fagor Intelligent Profile Editor (mini **CAD/CAM**)
- Tool Radius, Tool Length, Tool Wear compensation, 255-sets
- Simulation mode, dry run mode, and Solid 3D Graphics Display with zoom feature
- 10.4” High Resolution LCD color monitor
- Jog Mode & MDI Mode
- Tool offset and Work Coordinate Zero offset tables
- G-code Programming and Editing (on-line with interactive editor), plus M-codes
- WIN DNC offline software program
- Ballscrew pitch & backlash compensation
- Tele-diagnosis: Remote Instant Service capability through modem. (optional)
- Front-mounted USB port for program transfer (standard), Ethernet TCP/IP (optional)

Specifications & prices subject to change without prior notice.